

How to order

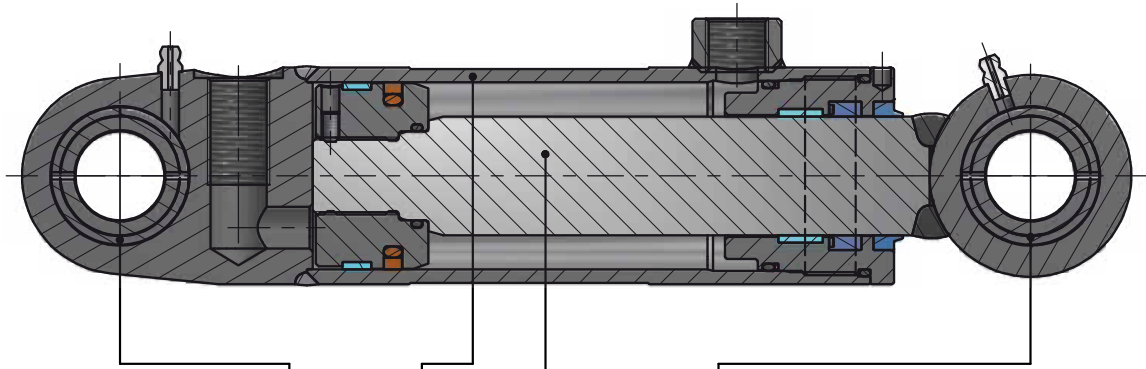

F1 - X - X - D / d x Stroke - X - X - X - (X)

Type

Rearmounting

Function E - D
E = Single-acting
D = Double-acting

Cylindertubediameter

Pistonrodmounting

Sealing type

Pistonroddiameter

SP - Special
Not stand. mess. from katalog

Pistonrodmaterial R = (Stainless steel)

Rearmounting:

- S** Spherical bearing
- C** Spherical composite bearing

Pistonrodmounting:

- S** Spherical bearing
- C** Spherical composite bearing
- AC** Spherical composite bearing adjustable

Sealing type

- 1** Standard, Polyurethan/Nitril
- 2** Low friction, PTFE (Bronze) / Nitril
- 3** High temp. PTFE (Bronze) / Viton
- 4** PTFE (carbon) / Viton
- 5** Special material qualities can be delivered on request

Quality Control



Advanced test equipment

